

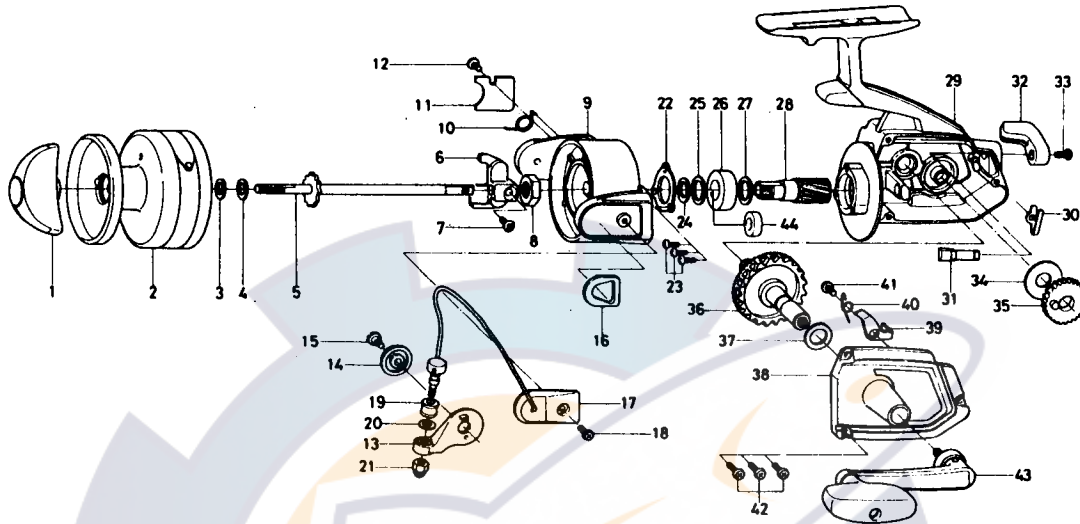

SPINNING REEL

B-250



LINE CAPACITY: 275 YDS. 12 LB. TEST (250m Dia. 0.35mm)

Key No.	Parts No.	Parts Name	Key No.	Parts No.	Parts Name
1	67402103	Drag knob	23	63516601	Pinion collar ret. washer screw
2	67315401	Spool assembly	24	63712822	Pinion washer A
3	63749000	Spool washer A	25	63728600	Pinion washer B
4	63749001	Spool washer B	26	66362611	Shaft Metal
5	67109113	Main shaft	27	63712822	Pinion adjusting washer
6	64810901	Oscillating slider	28	64024511	Pinion
7	63518901	Oscillating slider screw	29	67007301	Body
8	63408301	Rotor nut	30	61506731	Anti-reverse cam spring
9	62017701	Rotor	31	64604721	Anti-reverse cam
10	61435311	Bail spring	32	65413311	Anti-reverse lever
11	66326411	Bail spring cover	33	63522501	Anti-reverse lever screw
12	63511801	Bail spring cover screw	34	63746600	Oscillating gear washer
13	62308121	Arm lever	35	64132212	Oscillating gear
14	61303201	Bail holder cap	36	64133011	Drive gear
15	63631901	Arm lever screw	37	63712820	Drive gear washer
16	62103111	Balancer	38	67060601	Body cover
17	67251132	Bail	39	61109622	Anti-reverse claw
18	63516601	Bail holder screw	40	61442801	Anti-reverse claw spring
19	62502801	Line roller	41	63516102	Anti-reverse claw screw
20	63734501	Bail washer	42	63518501	Body cover screw
21	63408501	Bail nut	43	67459401	Handle
22	66347011	Pinion collar ret. washer	44	65015101	Pinion Collar